

FIELDPILOT[®]

USER MANUAL

Assisted Steering Hydraulic Installation Manual for
Vehicle Kit Number 91-02316
Fits only Ag-Chem TerraGator 1803



A Subsidiary of  Spraying Systems Co.[®]

FIELDPILOT®

Copyrights

© 2010 TeeJet Technologies. All rights reserved. No part of this document or the computer programs described in it may be reproduced, copied, photocopied, translated, or reduced in any form or by any means, electronic or machine readable, recording or otherwise, without prior written consent from TeeJet Technologies.

Trademarks

Unless otherwise noted, all other brand or product names are trademarks or registered trademarks of their respective companies or organizations.

Limitation of Liability

TEEJET TECHNOLOGIES PROVIDES THIS MATERIAL "AS IS" WITHOUT WARRANTY OF ANY KIND, EITHER EXPRESSED OR IMPLIED. NO COPYRIGHT LIABILITY OR PATENT IS ASSUMED. IN NO EVENT SHALL TEEJET TECHNOLOGIES BE LIABLE FOR ANY LOSS OF BUSINESS, LOSS OF PROFIT, LOSS OF USE OR DATA, INTERRUPTION OF BUSINESS, OR FOR INDIRECT, SPECIAL, INCIDENTAL, OR CONSEQUENTIAL DAMAGES OF ANY KIND, EVEN IF TEEJET TECHNOLOGIES HAS BEEN ADVISED OF SUCH DAMAGES ARISING FROM TEEJET TECHNOLOGIES SOFTWARE.

PREPARATION

1. Before beginning the installation, thoroughly clean the vehicle to remove dirt and contaminants that might get into the hydraulic circuit.
2. Park the vehicle on a clean, level floor with adequate clearance to work around.
3. Do not attempt to loosen any hydraulic fittings while the engine is running.
4. Allow the motor and the hydraulics to cool until it is no more than warm to the touch before proceeding.
5. Prior to loosening any hydraulic fittings, be sure to have the appropriate plugs and caps available in order to limit loss of hydraulic fluid from the open fittings.
6. Remove the hood and side panels around the engine compartment to allow access to the hydraulic system.



PREVENT HYDRAULIC SYSTEM CONTAMINATION. It is essential to thoroughly clean hydraulic system fittings and hose connections prior to disconnecting or removing them. Use a spray cleaner such as “Brake Clean” to prevent hydraulic system contamination. Note that o-rings used on ORB and ORFF type fittings may be damaged by solvent cleaners such as “Brake Clean”. If a fitting is to be cleaned internally, the o-ring should first be removed and cleaned with a fiberless cloth.

IMPORTANT!

TO AVOID EXCESS LEAKAGE, DO NOT TURN THE STEERING WHEEL WHILE THE FITTINGS ON THE MANUAL STEERING VALVE ARE DISCONNECTED.



WARNING: HOT, HIGH PRESSURE FLUID HAZARD. Hydraulic oil may be hot and under extreme pressure. To prevent serious injury or death, relieve system pressure and allow the system to cool before repairing or disconnecting. Wear proper hand and eye protection when searching for leaks, using wood or cardboard instead of hands. Keep all hydraulic components in good repair.











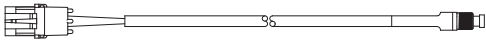

WARNING: PINCH POINT HAZARD! To prevent serious injury or death, avoid unsafe practice while manually operating hydraulic steering circuits. Keep others away and stay clear of mechanical steering linkages.

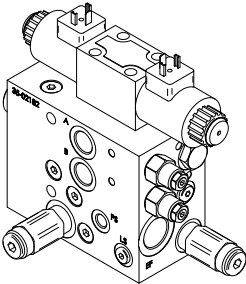
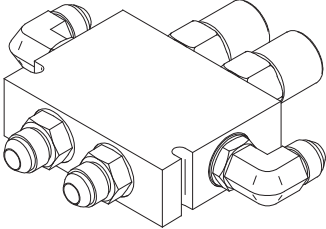
KIT CONTENTS

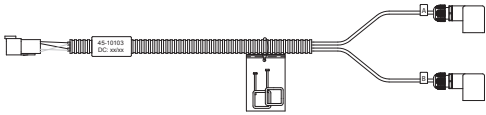
Unpack the installation kit and identify the required parts.

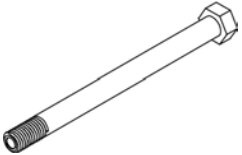
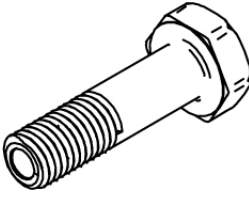
Item	Part Number	Description	Quantity
A	32-04040	Switch, Engage/Disengage.....	1
B	350-0024	Washer, Flat, 1/4" SST.....	4
C	350-0083	Nut, Whiz-Lock, 1/4"-20 SST.....	2
D	350-0136	Bolt Hex, 1/4"-20 X 2-1/2" SST.....	2
E	35-02182	Valve, FLDPLT, PWM OC, 4.0GPM.....	1
F	35-02155	Valve Counter Balance.....	1
G	45-07703	Harness, SCM.....	1
H	45-10103	Harness, Valve.....	1
I	60-04089	Bolt Hex, 3/8"-16 X 3-3/4" SST.....	2
J	60-04091	Bolt Hex, 5/8"-11 X 1.5" SST.....	1
K	60-07027	Nut, NyLock 3/8-16, SST.....	2
L	60-07028	Nut, Whiz-Lock, 5/8"-11 SST.....	1
M	65-05134	Bracket, Hyd. Block Mnt -.....	1
N	68-01144	Hose, Hyd - 1/2" x 47", #8FJIC x #8FJIC 90°.....	1
O	68-01222	Hose, Hyd - 1/2" x 22", #8FJIC x #8FJIC 90°.....	2
P	68-01223	Hose, Hyd - 1/2" x 25", #8FJIC x #8FJIC.....	2
Q	68-01224	Hose, Hyd - 1/2" x 32", #8FJIC x #8FJIC.....	1
R	68-02009	Adapter, Hyd. Run Tee - #8 JIC.....	3
S	68-02093	Adapter, Hyd. 90° EL - #8MJIC x #8FJIC.....	5
T	68-02094	Adapter, Hyd. - #8MJIC x #8MORB.....	5
U	68-02095	Adapter, Hyd. 90° EL - #8MJIC x #8MORB.....	2
V	68-02122	Adapter, Hyd. - #8MJIC x #12MORB.....	2
W	90-50013	Cable Tie Kit, 15.....	1
X	91-07011	Steering Wheel Switch Kit.....	1
Y	98-05116	Installation Manual, AG-CHEM 1803.....	1
Z	16-00001	Magnets, Self-Adhesive.....	12

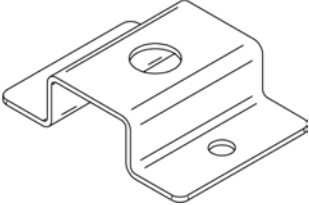
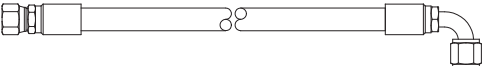
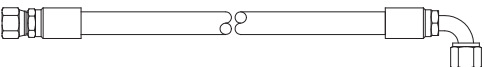
Item	Part #	Description	Illustration
A	32-04040	Switch, Engage/Disengage	
B	350-0024	Washer, Flat, 1/4" SST	
C	350-0083	Nut, Whiz-Lock, 1/4"-20 SST	
D	350-0136	Bolt Hex, 1/4"-20 X 2-1/2" SST	
E	35-02182	Valve, FLDPLT, PWM OC, 4.0GPM	
F	35-02155	Valve Counter Balance	
G	45-07703	Harness, SCM	
H	45-10103	Harness, Valve	

Item	Part #	Description	Illustration
I	60-04089	Bolt Hex, 3/8"-16 X 3-3/4" SST	
J	60-04091	Bolt Hex, 5/8"-11 X 1.5" SST	
K	60-07027	Nut, NyLock 3/8-16, SST	
L	60-07028	Nut, Whiz-Lock, 5/8"-11 SST	
M	65-05134	Bracket, Hyd. Block Mnt -	
N	68-01144	Hose, Hyd - 1/2" x 47", #8FJIC x #8FJIC 90°	
O	68-01222	Hose, Hyd - 1/2" x 22", #8FJIC x #8FJIC 90°	
P	68-01223	Hose, Hyd - 1/2" x 25", #8FJIC x #8FJIC	
Q	68-01224	Hose, Hyd - 1/2" x 32", #8FJIC x #8FJIC	

Item	Part #	Description	Illustration
R	68-02009	Adapter, Hyd. Run Tee - #8 JIC	
S	68-02093	Adapter, Hyd. 90° EL - #8MJIC x #8FJIC	
T	68-02094	Adapter, Hyd. - #8MJIC x #8MORB	
U	68-02095	Adapter, Hyd. 90° EL - #8MJIC x #8MORB	
V	68-02122	Adapter, Hyd. - #8MJIC x #12MORB	
W	90-50013	Cable Tie Kit, 15	
X	91-07011	Steering Wheel Switch Kit	
Y	98-05116	Installation Manual, AG-CHEM 1803	
Z	16-00001	Magnets, Self-Adhesive	

Figure 1-1: Hydraulic Diagram



Hydraulics as installed
 1803 s/n 1814366
 Cummins engine
 Eaton-Fuller Transmission
 January 2008 WWR

New Hoses _____

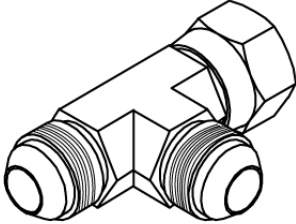
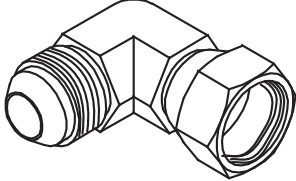
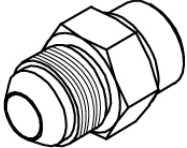
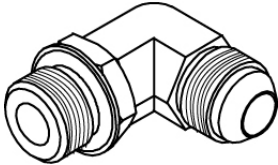
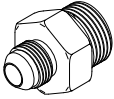
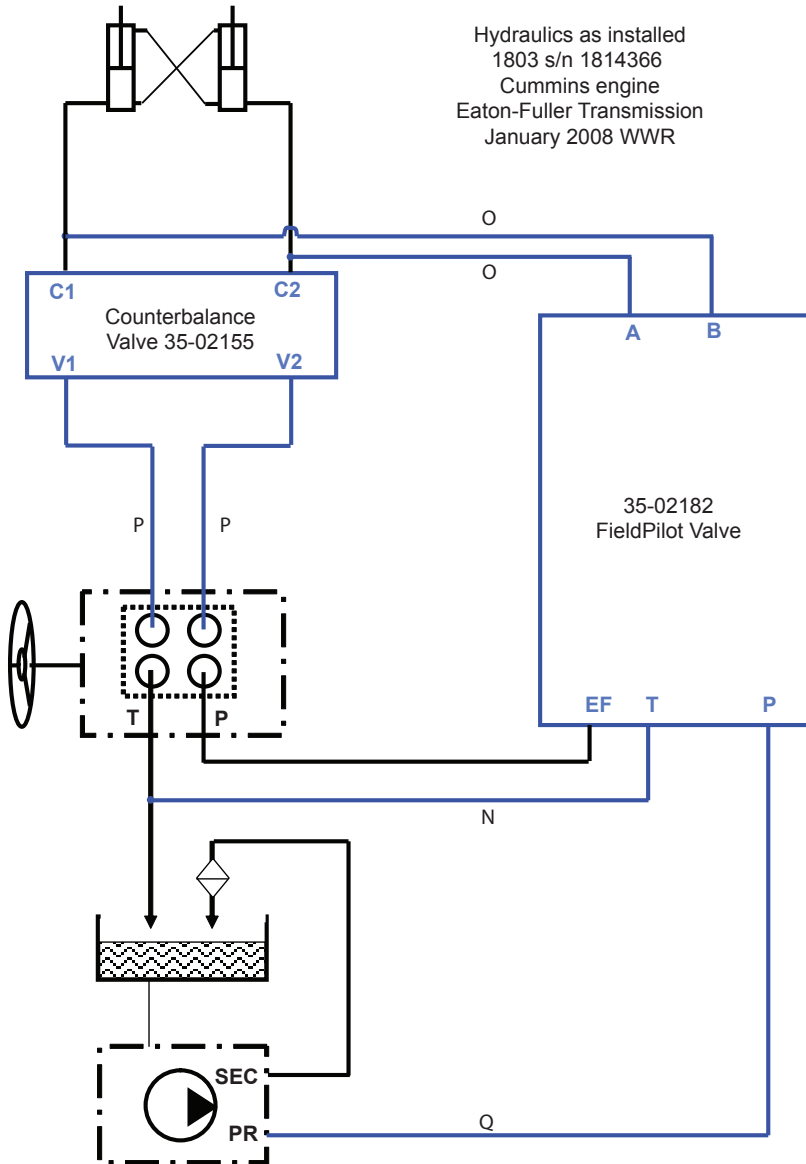
INSTALLATION



If there are questions concerning the installation of the FieldPilot system on this vehicle, or due to the changes in component specifications the parts supplied in the kit are not exactly as presented in this document, please contact your dealer or TeeJet Customer service representative for clarification before installation. TeeJet Technologies is not responsible for misuse or incorrect installation of the system.

NOTE: BE VERY CAREFUL TO ABSOLUTELY SECURE ALL CABLES AND HOSES SO THAT THEY DON'T INTERFERE WITH THE MANY MOVING PARTS OF THE MACHINE!

1. PREPARE THE FIELDPILOT VALVE

Make sure the valve block is clean and dust free. Work on a clean bench. Remove the plastic plugs and install the adapters (**V**) in the P and EF ports. Install adapters (**S**) on the ends of these.

Install two adapters (**T**) into the T, A and B ports. Install adapters (**S**) on the ends of these.

NOTE: All references to left and right are stated as if the user is seated in the driver's seat.

Figure 1-2: Preparing Hydraulic Control Block

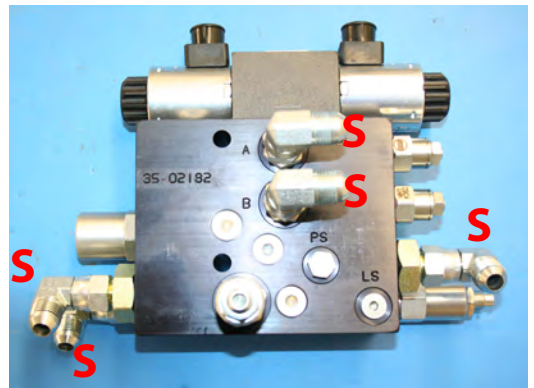

2. INSTALL MOUNTING BRACKETS ON FIELDPILOT VALVE.

Using the bolts and nuts (**I** and **K**) attach the valve block to the bracket (**M**) so that the ribbed part of the bracket is pointed away from the valve block.

Figure 1-3: Install the Mounting Bracket

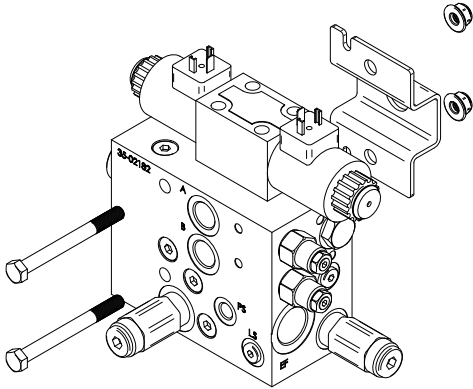

3. MOUNT VALVE BRACKET ON VEHICLE

The valve is mounted on the rear face of the tool cabinet located on the left side of the vehicle. Hold the valve and bracket assembly in place to ensure clearance for the hoses (which will be attached later) and to position the valve so it does not protrude outside the clearance of the tool box. Use the position of this assembly to choose the best place to drill a hole in the forward face of the toolbox. Drill a single hole large enough to accept the 5/8 inch mounting bolt (**J**), 11/16" is recommended.

Use the 5/8-11 x 1.5" bolt and Nyloc nut (**J** and **L**) to firmly attach the valve and bracket assembly to the toolbox.

Figure 1-4: Mount Valve Bracket on Vehicle

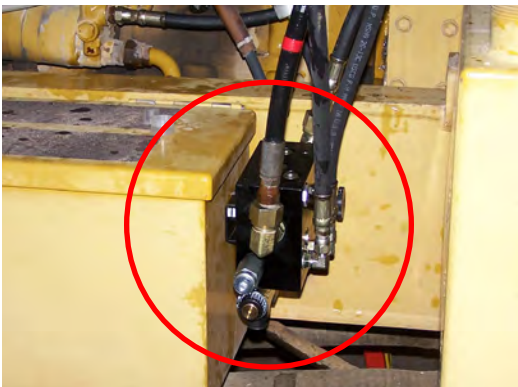

4. PREPARE COUNTERBALANCE VALVE (B) BLOCK

Make sure the valve block is clean and dust free. Work on a clean bench. Remove the plastic plugs and install the straight fittings (T) in ports C1 and C2. Install the elbow adapter fittings (U) in ports V1 and V2. Orient the elbow adapters so that they are pointing the opposite direction from the fittings in ports C1 and C2. Install #8 JIC Run Tee fittings (R) on the straight adapters in ports C1 and C2.

Figure 1-5: Prepare Counterbalance Valve Block



5. MOUNTING THE COUNTERBALANCE VALVE

Hold the valve in position on the front of the left side of the cab. Check to be sure the hoses from both the orbital and the FieldPilot Valve (E) will reach the correct ports on the counterbalance. Mark the bolt holes and drill two 5/16 holes through the cab. Be sure to check for obstructions inside the cab.

Figure 1-6: Mounting The Counterbalance Valve

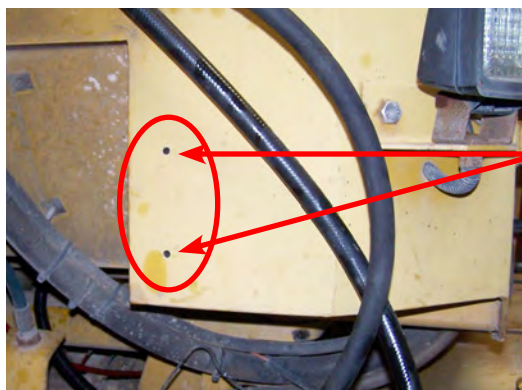

Bolt Holes

Using the bolts, washers, and nuts (B, C, and D) attach the valve block to the front of the cab as shown. Once the valve assembly is mounted, the straight fittings in C1 and C2 should be facing toward the outside of the vehicle with the center tap of the Run Tees facing forward. The elbow adapter fittings in V1 and V2 should be facing toward the engine compartment.

Figure 1-7: Mounting the Counterbalance Valve, Continued

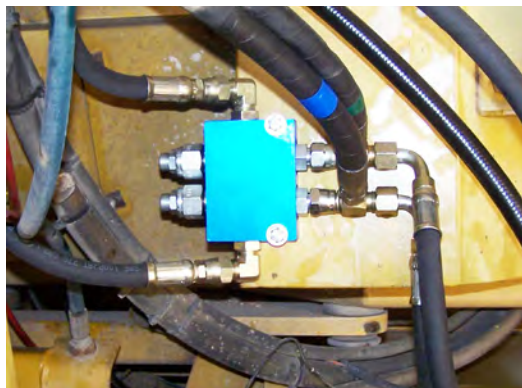

6. PREPARE PORTS ON STEERING ORBITAL VALVE

The Pressure and Tank ports on the steering orbital valve are the two ports on the top of the steering orbital valve. The Tank port is the one closest to the firewall of the cab. The left and right steering orbital valve ports are underneath the Pressure and Tank ports.

Figure 1-8: Steering Output Valve

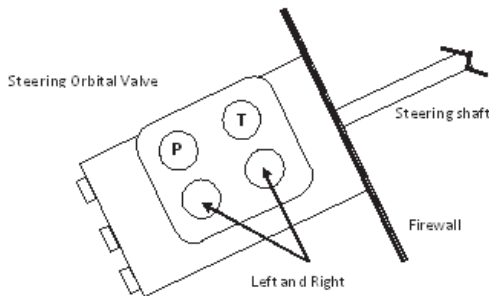

Remove the hoses from the left and right steering ports. Place a temporary cap over these (#8 MJIC fittings) and plug in the ends of the hoses. Temporarily remove the hose from the T port and install a # 8 JIC Run Tee (**R**) on the adapter fitting on the T port. Reconnect the original hose from the T port to the end of this Run Tee.

Figure 1-9: Mounting The Counterbalance Valve



Run Tee on the Tank Port

7. FIELDPILOT VALVE HOSE CONNECTIONS

The Pressure port of the FieldPilot Valve (E) will be connected to the PR port on the steering pump. Refer to the hydraulic system diagram Figure 1-1 to understand where the FieldPilot Valve (E) should fit in the system.

Figure 1-10: Pressure Line Connection

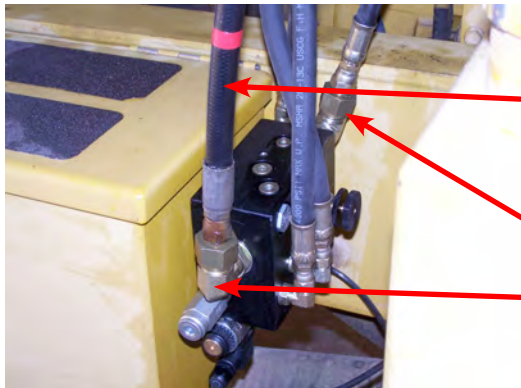

Hose removed from PR port of the pump
Pressure
Excess Flow

Remove the hose from the PR port on the pump. This hose is then connected to the EF port of the FieldPilot Valve (E). Install hose (Q) between the PR port on the pump and the P port on the FieldPilot Valve (E).

Figure 1-11: PR Port of the Steering Pump



PR port on the steering pump

Install hose **(N)** to the T port of the FieldPilot Valve **(E)**. Install the #8, 90° end of the hose to the branch of the Run Tee, previously installed on the T port of the orbital steering valve.

Figure 1-12: Tank Return Hose



Install hoses **(O)** to the A and B ports of the FieldPilot Valve **(E)**. The 90° ends of hoses **(O)** are routed up to the counterbalance valve **(F)**.

Figure 1-13: Tank Return Hose (Continued)

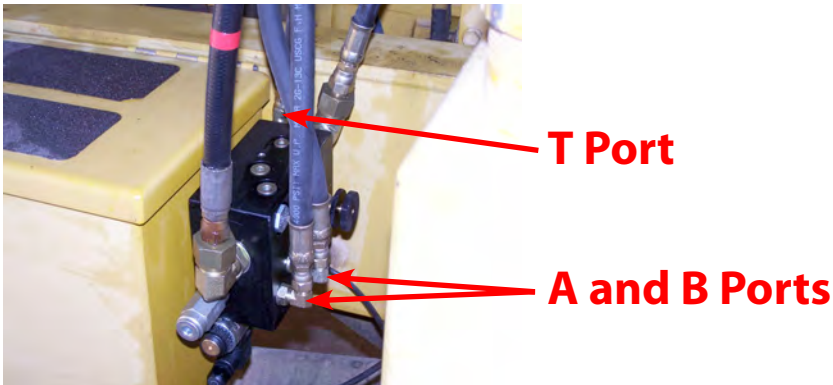

8. INSTALL STEERING OUTPUT HOSES TO THE COUNTERBALANCE VALVE

Hoses (P) are first connected to the left and right steering ports on the orbital steering valve with the other end connected to ports V1 and V2 of the counterbalance valve (F). The two hoses (O) from the A and B ports of the FieldPilot Valve (E) are now connected to the ends of the Run Tee adapters installed on ports C1 and C2 of the counterbalance valve (F). Finally, the two original hoses removed from the left and right steering ports on the orbital steering valve are connected to the branches of the two Run Tee fittings on the C1 and C2 ports of the counterbalance valve (F).

Figure 1-14: Install Steering Output Hoses

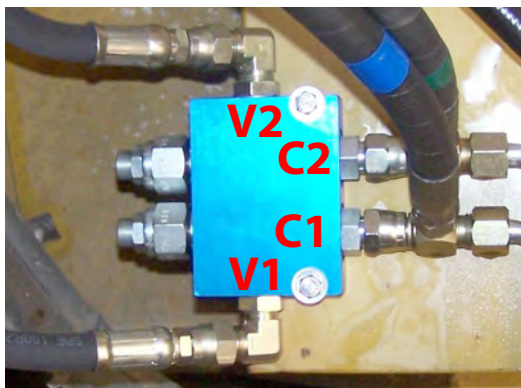

This completes the hydraulic kit installation. Be sure all fittings are tight and all hoses are supported. Also ensure there are no chafe points in the hose runs.

9. INSTALL STEERING DISENGAGE SENSOR

The steering disengage kit (X) along with item (Z) is used to automatically disengage FieldPilot when the steering wheel is turned. The magnets mount to the steering as shown. The sensor must be mounted with a 1/8" clearance from the magnets.

Figure 1-15: Install Steering Disengage Sensor

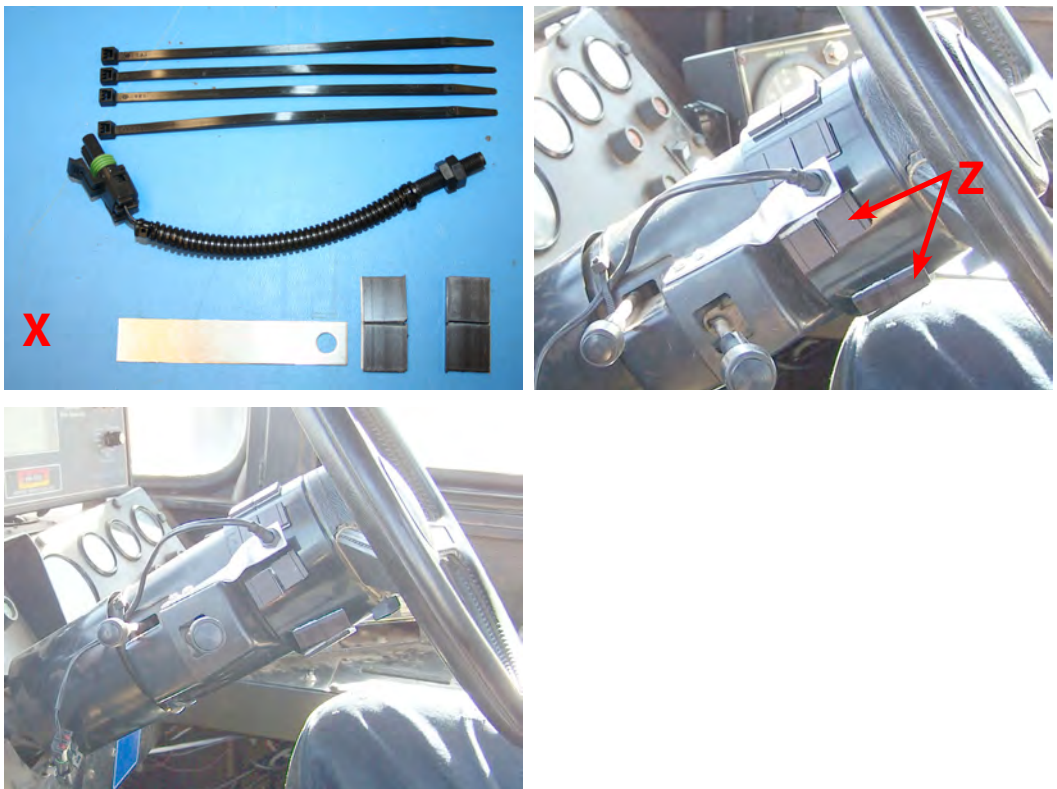

10. INSTALLATION OF ENGAGE/DISENGAGE SWITCH

Connect item **(A)** to the connector on the SCM harness labeled Remote Engage/Disengage. Install the push button in a location that is easily accessible during operation of the machine. This switch **(A)** is not required if the optional foot switch 32-04020 is used.

Figure 1-16: Engage/Disengage Switch



11. INSTALL THE VALVE CONTROL CABLE

Install the electronic valve control cable at the FieldPilot valve by attaching the DIN connectors to the individual coils. Connect wire A to the left hand solenoid and wire B to the right hand solenoid.

NOTE: If the vehicle automatically steers the wrong way when tested, exchange the connector positions.

Route this cable under the cab and then into the cab through one of the exposed holes in the compartment on the right rear of the cab. Secure the cable with wire ties as necessary.

12. RECOMMENDED ELECTRONICS INSTALLATION

The Steering Control Module (SCM) should be mounted securely to the floor of the cab. A good location is to the right of the seat near the rear of the cab. The control console can be mounted to the operator's preference. The GPS antenna should be mounted as far forward as possible on top of the cab on a metal surface of at least 4" square.

Figure 1-17: Recommended Electronics Installation



13. VERIFY OPERATION OF HYDRAULICS AND SET THE STEERING CONTROL RATE

Clean and pick up the area around the vehicle and make certain that it is safe to operate. Start the engine and check hydraulic connections for leaks. Rotate the steering wheel from one extreme to the other and back to center, check for leaks. While steering through the extremes of movement, check the cables and hoses for wear points and strain, adjust as necessary.

The oil flow rate adjustment is accomplished through the Matrix console. The target lock to lock time is 7 seconds. Refer to the Matrix manual for further instructions.

Use the electronic steering control console to perform the left to right steering test. Count the seconds to move the wheels from full left to full right and also in the opposite direction. The vehicle should be moving forward very slowly during these tests so there is not excessive side pressure on the tires. If you find that the machine steers in the opposite direction from that being commanded in this steering test sequence, switch the valve connectors at the FieldPilot valve.

NOTE: To activate the manual overrides, a tool such as a small screwdriver or allen wrench must be inserted into the end of the coil to depress the override button.



WARNING: PINCH POINT HAZARD! To prevent serious injury or death, avoid unsafe practice while manually operating hydraulic steering circuits. Keep others away and stay clear of mechanical steering linkages.

14. COMPLETE ELECTRONIC INSTALLATION

Refer to the owner's manual supplied with the automated steering system to complete the electronic installation and setup.

FIELDPILOT®

USER MANUAL

A series of equipment-specific hydraulic installation kits have been developed to work in conjunction with your assisted steering system. This kit contains the necessary components and instructions to install assisted steering hydraulics on the AgChem (AGCO) TerraGator 1803 Floater Chassis (when equipped with Cummins engine and Eaton-Fuller Transmission). Please review this manual thoroughly before beginning the installation process.



1801 Business Park Drive
Springfield, Illinois 62703 USA
Tel: (217) 753-8424 • Fax: (217) 753-8426
www.teejet.com

A Subsidiary of  *Spraying Systems Co.*®

98-05116 R2
© TeeJet Technologies 2010